

PLASMA PROCESS GROUP, INC.

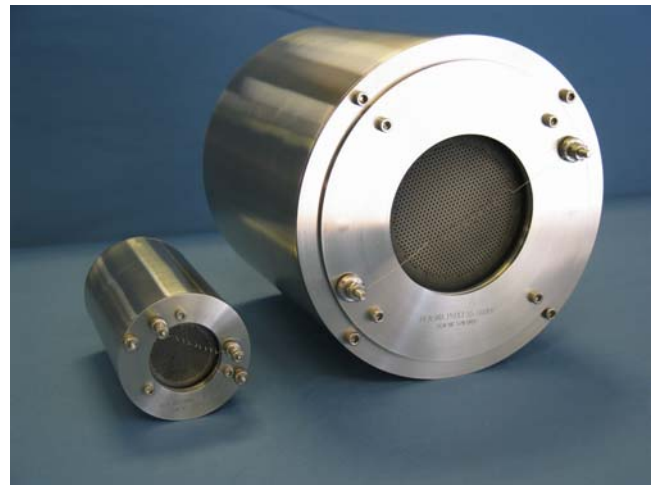

3 cm and 8 cm
Ion Beam Source Manual
DC Filament Cathode / Filament Neutralizer



plasma process group

Copyright © 2009 by Plasma Process Group, Inc. All rights reserved
1714 Topaz Drive, Ste. 110, Loveland, CO 80537
Phone 970-663-6988 • Fax 970-669-2312

No part of this publication may be reproduced without prior written permission

Date: July 2009

Revision: D

Table of Contents

| | |
|---|----|
| Chapter 1: Introduction | 1 |
| Limited Warranty | 2 |
| Service and Technical Contact Information | 3 |
| Chapter 2: Theory of Operation | 5 |
| Source Parameter Definitions | 9 |
| Ion Beam Properties | 13 |
| References and Recommended Readings | 15 |
| Chapter 3: Installation Procedures for 3 cm Source | 17 |
| Chapter 4: Installation Procedures for 8 cm Source | 27 |
| Chapter 5: Operation | 41 |
| Chapter 6: Troubleshooting | 47 |
| Chapter 7: Appendix A – Specifications and Technical Drawings | 55 |
| Chapter 8: Appendix B – Source data sheet | 63 |



Introduction

Thank you for purchasing an ion beam source from Plasma Process Group!

This Manual covers the installation and operation of our 3 cm and 8 cm DC ion beam sources. It is assumed the source will be controlled using our IBEAM power supply, however this manual will be applicable if other power supplies are used.

Ion beam technology was developed at NASA in the 1960's as a means of producing thrust on spacecraft. Several spacecraft have used ion beam thrusters for station keeping and trajectory control. Recently, the spacecraft Deep Space 1, demonstrated the long duration performance capabilities and propulsion advantages of ion-beam thrusters. There are numerous publications about ion beam thrusters and some are given here for the interested reader [1-3].

Ion beam sources also have numerous terrestrial applications. In the past decade, ion beams have been used for depositing wear resistant diamond-like carbon coatings on mechanical and optical hardware. They have also been used to fabricate the read/write heads used in computer hard-drives and thin-film optical filters for telecommunication applications. A select few publications involving ion beam deposition technology are given here for the interested reader [4-7].

For this manual, it is assumed the operator of the ion beam source has a basic knowledge and/or technical skills with electrical discharge devices. If necessary, we encourage a review of the introductory chapters for the following references [8-10]. A basic physical knowledge of plasma behavior is required, however, the mathematical descriptions will be kept to a minimum. For any technical assistance, please contact us.

We at Plasma Process Group hope that using your new ion beam source will produce rewarding results.

Limited Warranty

Our workmanship warranty:

All equipment manufactured and sold by Plasma Process Group Inc is warranted to be free of defects and workmanship when shipped. The warranty on all equipment is for one year commencing (a) on final acceptance or (b) 30 days from shipping, whichever occurs first. This warranty covers the cost of parts and labor. Expendable and consumable items, such as grid assemblies, RFN collectors and discharge chambers are excluded from this warranty. This warranty supersedes all other warranties, expressed or implied. Plasma Process Group Inc assumes no contingent liability for damages or loss of production.

Expendable items, including, but not limited to, grid assemblies, RFN collectors, discharge chambers, filaments, fuses, o-rings and seals are specifically excluded from the foregoing warranties and are not warranted.

Seller assumes no liability under the above warranties for equipment or system failures resulting from (1) abuse, misuse, modification or mishandling; (2) damage due to forces external to the equipment including, but not limited to, flooding, power surges, power failures, defective electrical work, transportation, foreign equipment/attachments or Buyer-supplied replacement parts or utilities or services such as process gas; (3) improper operation or maintenance or (4) failure to perform preventative maintenance in accordance with Seller's recommendation (including keeping an accurate log of preventative maintenance). In addition, this warranty does not apply if any equipment or part has been modified without the written permission of Seller.

Technical Contact Information

For Service or Repair contact:

Plasma Process Group Inc (PPG)
www.plasmaprocessgroup.com

Please supply the following information:

- Product
- Model and serial number
- Date Purchased
- Detailed description of problem
- Contact person

If the product is to be returned to PPG for repair you will be assigned a **Return Authorization** number (RA), warranty status of the equipment and shipping information to return the product. The RA number should be attached to the outside of the shipping container. A purchase order number should be included should the equipment not be under warranty. After PPG receives the equipment a firm quote and estimated repair time will be given prior to work being started.

Theory of Operation

The function of an ion beam source is to produce ions and accelerate these ions to high velocities so they are ejected downstream from the source. The ejected ions are directed to form a “beam” in which the ions are mono-energetic with velocities on the order of km/s. An ion beam source consists of four (4) key elements:

Discharge Chamber, Electron Source, Grids, and Neutralizer.

Presented in Figure 1 is a schematic of an ion beam source. Basically, the source is operated by introducing the source gas into the **discharge chamber**. An **electron source** is used to ionize the gas and establish a plasma. Recall, a plasma is an electrically conductive gas where the density of ions and electrons are approximately equal. Ions created in the **discharge chamber** are then accelerated to high velocities with the source **grids**. A **neutralizer** is placed downstream from the source where it emits electrons to balance the number of positive ions which leave the source.

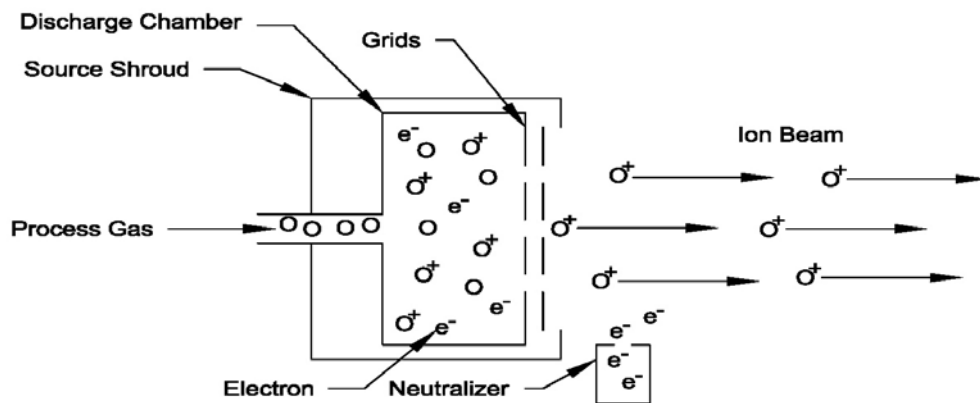

Figure 1. Schematic of an ion beam source.

The different types of ion beam sources are delineated by the specifics of the four (4) key elements. In this introduction, ion beam sources will be classified as either direct current (DC) or radio frequency (RF). A brief, physical description of each of the four elements is presented below.

Discharge Chamber - the discharge chamber is where the source gas is ionized.

For DC sources, the discharge chamber is referred to as the **body**. The body will have a magnetic field produced using permanent magnets. The purpose of the magnetic field is to control the motion of electrons such that they have several ionizing collisions with the source gas occur before being collected on the anode.

For RF sources, the discharge chamber consists of a dielectric material permeable to the RF field produced by the antenna. The RF field ionizes the source gas introduced within the discharge chamber.

Electron Source – mechanism by which electrons are produced to ionize the source gas.

For DC sources, the electron source can be either a hot filament or a hollow cathode. Typically, a filament consists of a tungsten wire which is heated to emit electrons. A hollow cathode is a device which produces electrons by locally ionizing its own feed gas. The electrons from either the filament or hollow cathode are then used to ionize the source gas, which, for the hollow cathode case, may be the same gas it used. The electrons have several ionizing collisions before being collected at the anode surface in a DC source.

For RF sources, the RF field energizes free electrons in the working gas. The energetic electrons have ionizing collisions with the source gas thereby producing ions and additional electrons. As ions leave the discharge chamber, electrons are collected on the screen grid surface.

Grids – the electrostatic apertures by which the ions from the discharge are extracted.

Grids are electrodes separated from each other by a few millimeters. Each grid has several apertures that are aligned and allow for the extraction of ions. The grid closest to the discharge chamber is referred to as the **screen (or S) grid**. Moving downstream, the next grid is referred to the **accelerator (or A) grid**. On some sources, a third grid is used which is the furthest downstream from the discharge chamber and it is referred to as the **decelerator (or D) grid**.

The grid assembly extracts ions from the discharge chamber by applying specific potentials (or voltages) to each grid. A potential (or voltage) diagram of the ion acceleration process is presented in Figure 2. First, the S grid is biased positive (**beam voltage**) with respect to ground and consequently the plasma in the discharge chamber is also biased positive with respect to ground. Next, the A grid is biased negative (**accel voltage**) with respect to ground and establishes an electric field along the source centerline. Positive ions in the discharge chamber that drift close to this electric field are accelerated.

Even if the D grid is not used, the potential downstream from the source is ultimately approximately zero. Depicted in Figure 2 is the electric potential for a 3-grid assembly. The D grid potential is typically held at ground potential (or 0 V). The accelerated ions then decelerate after passing the A grid and exit the aperture with a net, ion energy of approximately **beam voltage**. As depicted in Figure 2, electrons either located in the discharge chamber or downstream from the source are separated due to the established electric field.

Ions extracted through the grid apertures comprise individual beamlets and a typical grid assembly will have numerous apertures. As a result, individual beamlets combine to form a more, broad ion beam.

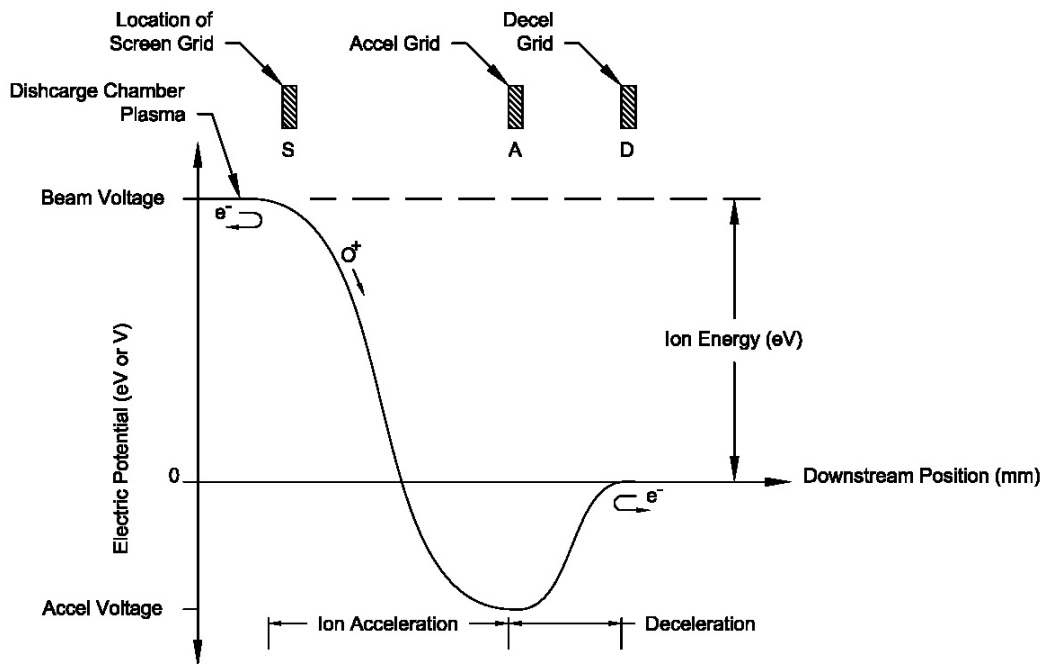

Figure 2. Schematic of the ion acceleration process.

Neutralizer – an electron source downstream from the ion source.

For DC sources, the neutralizer can be a hot filament, hollow cathode, or plasma bridge type. A plasma bridge neutralizer (PBN) is where a hot filament is placed in a smaller discharge chamber through which an inert process gas is supplied. For RF sources, the neutralizer can be either a PBN or RF type. The RF neutralizer (RFN) consists of a small discharge chamber with an RF coil. The RFN utilizes a collector and keeper to emit electrons.

The purpose of the neutralizer is to emit electrons into the environment downstream from the ion beam source. The emitted electrons provide a charge balance for the ions leaving the source. Typically, more electrons are emitted from the neutralizer than ions from the source. This is done to minimize and/or eliminate the space or surface charging that may occur. In most situations, electrons from the neutralizer do not directly combine with the ions in the beam to form high energy neutrals.

Source Parameter Definitions

As electrical devices, ion beam sources require power supplies. Presented in Figures 3 and 4 are the electrical schematics for typical DC and RF sources, respectively.

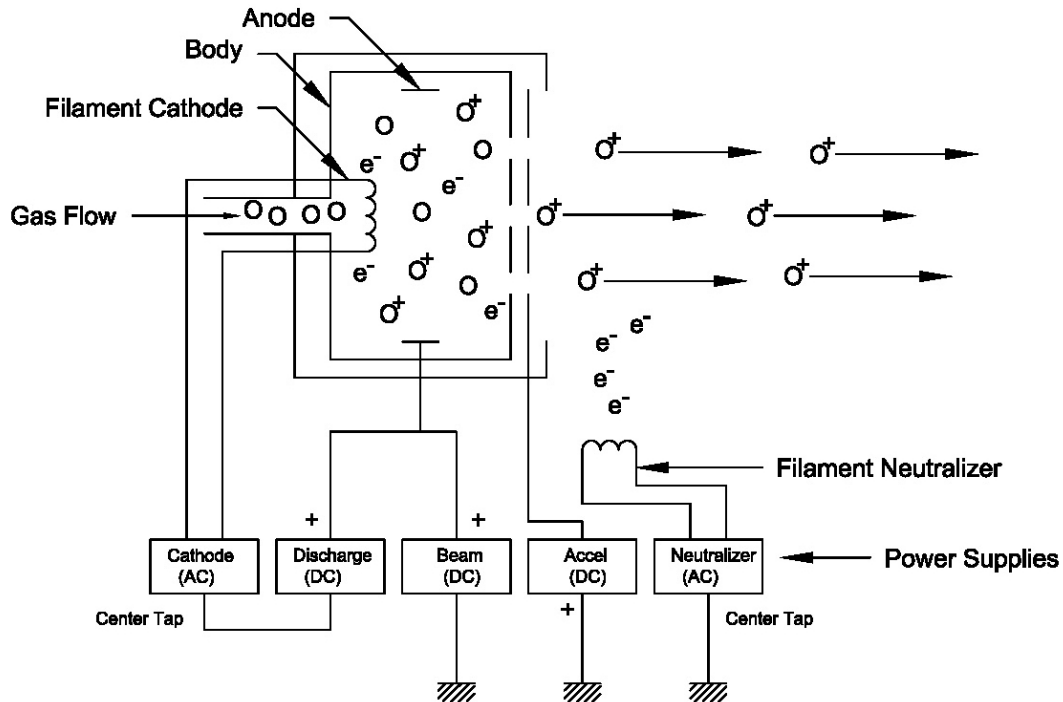

Figure 3. The electrical schematic for a filament DC source.

In Figure 3, the electrical connections for a filament cathode and filament neutralizer DC source are presented. The cathode is heated using an AC power supply. Electrons leaving the filament are collected at the anode with the discharge supply, a DC bias supply. The beam supply, also a DC bias supply, is also connected to the anode and biases the discharge plasma positive with respect to ground. Not illustrated, but commonly used is a resistor placed between the body and anode. The body resistor establishes the proper bias between the anode and body and thereby directs electrons to be collected on the anode surface. The accelerator supply, a DC type supply, biases the accel grid negative with respect to ground. Finally, the neutralizer filament is heated using an AC power supply.

In Figure 4, the electrical connections for a RF source with RF neutralizer are presented. The RF coil for the discharge chamber is energized by the RF supply and is tuned by using a matching network. The beam supply, a DC bias supply, is connected to the screen (S) grid in order to bias the discharge plasma positive with respect to ground. The accelerator supply, a DC type supply, biases the accel grid negative with respect to ground. Finally, the RF

neutralizer utilizes an RF supply and matching network for its own discharge and additional DC supplies to emit electrons.

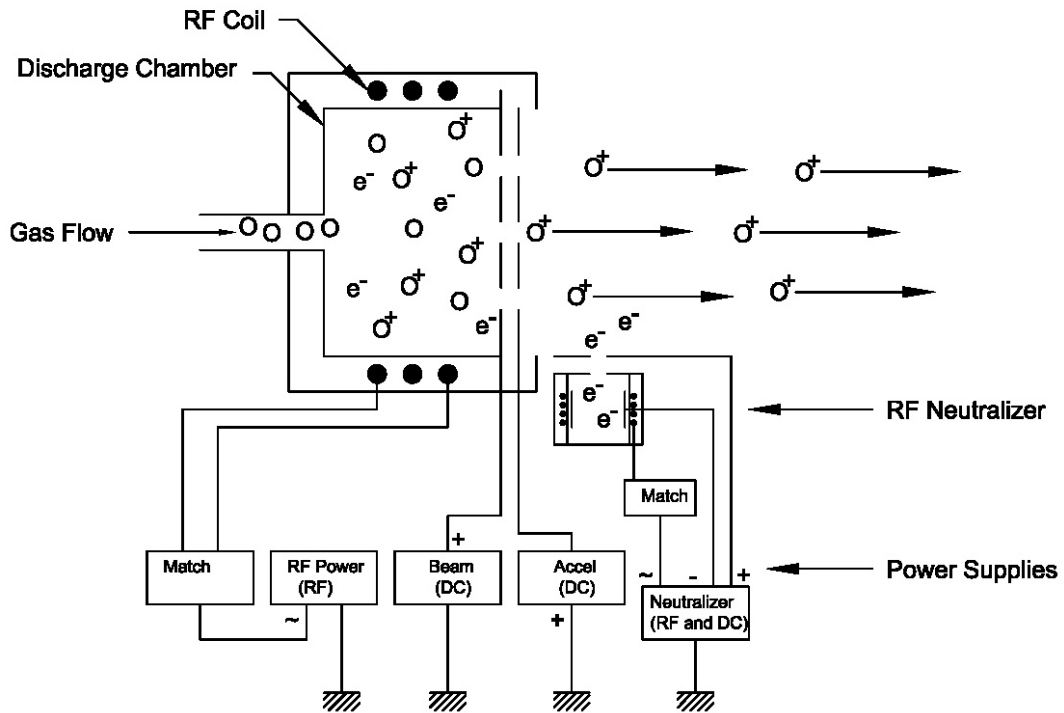

Figure 4. Electrical schematic for a RF source.

Additional power supply details and source parameters are presented in Tables 1 and 2. Ion beam source parameters used by both DC and RF sources are presented in Table 1. Specific parameters that pertain to DC filament, DC hollow cathode, and RF sources are outlined in Table 2. Actual values for these source parameters will be specific to source type, size, grids, and process. Typical values will be given where appropriate.

Table 1. Ion beam parameters for all sources.

| Parameter | Definition | Unit |
|------------------------------|---|------|
| All Sources | | |
| Source Gas Flow | Process gas delivered to the discharge chamber. | sccm |
| Beam Voltage | Positive voltage applied to the discharge plasma.† | V |
| Beam Current | The total ion current extracted, or leaving the source. | mA |
| Accel Voltage | Negative voltage applied to the accelerator (A) grid. | V |
| Accel Current | Charge-exchange current collected by accelerator (A) grid. | mA |
| A/B Ratio | Ratio of accel to beam currents. Indicates quality of grid focusing. Typical A/B is < 10%. | % |
| Neutralizer Emission Current | The electron current emitted by the neutralizer. | mA |
| E/B Ratio | Ratio of neutralizer emission to beam currents. Typical E/B is >100% to minimize space charging, surface charging and arcing. | % |

† For DC sources, beam voltage is applied to the anode. For RF sources, beam voltage is applied to the screen (S) grid.

Table 2. Ion beam parameters for specific types of sources.

| Parameter | Definition | Unit |
|--|---|------|
| DC Filament Cathode (FC) / Filament Neutralizer (FN) | | |
| Cathode Filament Current | The electrical current applied to the filament cathode. This current heats the filament so that electrons are emitted from its surface. | A |
| Discharge Voltage | The voltage established between the filament cathode and anode. This determines the electron energy for ionizing collisions in the discharge chamber. | V |
| Discharge Current | The electrical current established in the discharge chamber between the filament cathode and the anode. This current controls the ion production rate and to first order, the beam current. | A |
| Neutralizer Filament Current | The electrical current applied to the filament neutralizer. This current heats the filament so that electrons are emitted from its surface. | A |
| DC Hollow Cathode (HC) / Hollow Cathode Neutralizer (HCN) | | |
| Cathode Heater Current | The electrical current applied to the HC heater. | A |
| Cathode Keeper Voltage | The voltage established between the HC's body and keeper. | V |
| Cathode Keeper Current | The electrical current between the HC's body and keeper. | mA |
| Discharge Voltage | The voltage established between the HC body and anode. This determines the electron energy for ionizing collisions in the discharge chamber. | V |
| Discharge Current | The electrical current established in the discharge chamber between the HC body and the anode. This current controls the ion production rate and to first order, the beam current. | A |
| Neutralizer Heater Current | The electrical current applied to the HC heater. | A |
| Neutralizer Keeper Voltage | The voltage established between the HC's body and keeper. | V |
| Neutralizer Keeper Current | The electrical current between the HC's body and keeper. | mA |

Table 2. Ion beam parameters for specific types of sources continued.

| Parameter | Definition | Unit |
|-------------------------------------|--|------|
| RF with RF Neutralizer (RFN) | | |
| RF Forward Power | The RF power applied to the matching network. This power controls the ion production rate and therefore, the beam current. | W |
| RF Reflected Power | The RF power reflected from the matching network. Typically, the reflected power is <1% of the forward power. | W |
| RFN Forward Power | The RF power applied to the matching network. | W |
| RFN Reflected Power | The RF power reflected from the matching network | W |

Ion Beam Properties

For ion beam deposition applications, it is necessary to know the energy of the ions leaving the source and the dose that they strike a target downstream.

Ion Energy

The ejected ions from an ion beam source are considered mono-energetic and as depicted by Figure 2, the total ion energy is approximately the beam voltage. In order to illustrate the importance of this aspect, plotted in Figure 5 are two types of energy distributions. The ions in a typical electrical discharge device will have a range of energies that form a distribution that is thermalized; also referred to as Maxwellian. A Maxwellian energy distribution is plotted in Figure 5 where the number of ions is plotted for various energies. For comparison purposes, the energy distribution from an ion beam source is also plotted. Ions that leave the source have a limited energy range, selected by the beam voltage, and are referred to as mono-energetic. The significant attribute of the ion beam source is that energies of the ions can be adjusted by selecting different beam voltages, whereas, a Maxwellian discharge will have only limited adjustment in its energy distribution. The beam voltage range is typically 100 to 1500 V.

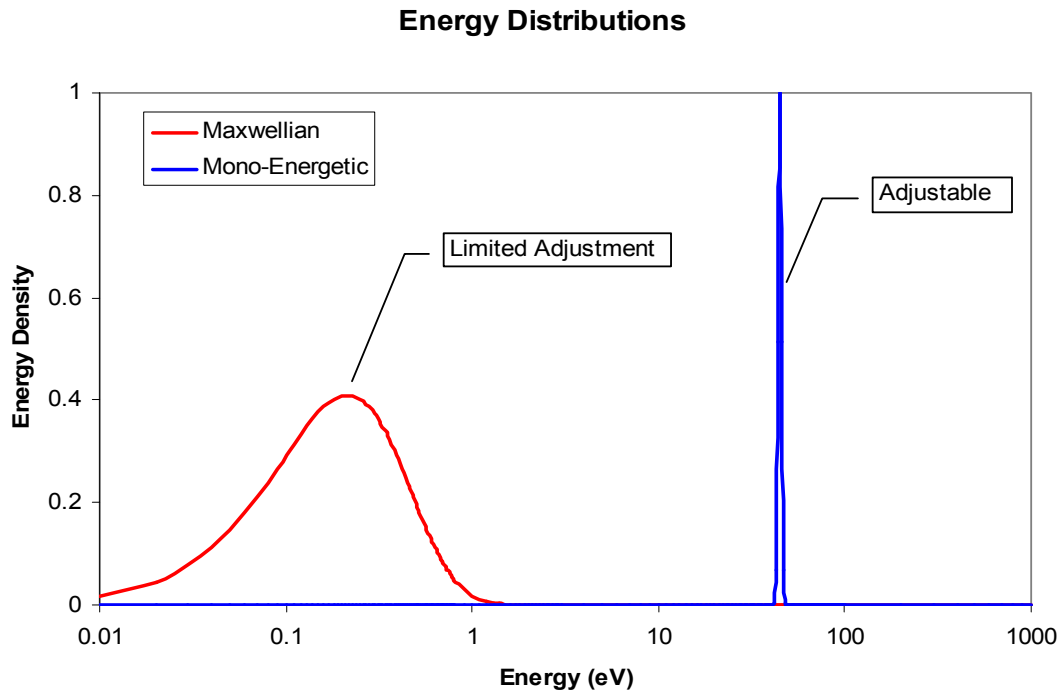

Figure 5. Two types of energy distributions: Maxwellian and Mono-Energetic.

Ion Dose

A measurement of the beam current is also an indication of the number of ions leaving the source. In most applications, it is important to determine the number of ions striking a specific location downstream, such as a target or substrate. This number is also referred to as the dose or flux density. The actual dose downstream from the source is determined by the ion beam focusing characteristics or ion optics.

Ion optics are determined by the beam current and voltage, accel voltage, and grid geometry (i.e. grid thickness, spacing, and shape). In general terms, the ion beam diverges, or spreads out, as it leaves the source. Custom grids can be fabricated to control this divergence and focus the ion beam. Ion optics is a rather detailed subject, and therefore, only brief, general rules of thumb are presented below for a typical grid set.

- 1) The divergence increases (the beam spreads out) when the accel voltage is increased.
- 2) The divergence can decrease at higher beam voltages.

Due to the complex nature of ion optics, the beam dose is best determined by measuring it using a Faraday type probe. Recall, a Faraday probe is a small electrode biased negative, usually about 40 V or so, to measure ion current and repel electrons. The probe is typically placed downstream from the source and swept through the beam to measure ion current at locations of interest. The ion current to the probe is divided by the area of the probe to determine the dose of the ion beam in mA/cm².

References

- [1] Wilbur, P.J., V.K. Rawlin and J.R. Beattie, "*Ion Thruster Development Trends and Status in the United States*," J. Prop. and Power, V. 14, No. 5, Sept.-Oct. 1998, pp. 708-715.
- [2] Rayman, M. D., P.V. Varghese, "*The Deep Space 1 Extended Mission*," *Acta Astronautica*, V. 48, No 5-12, 2001, pp. 693-705
- [3] Kaufman, H.R., R.S. Robinson, "*Broad-Beam Ion Sources*," Handbook of Plasma Processing Technology, pp. 183-193, Noyes Pub., New Jersey, 1990.
- [4] Wilbur, P. and B. Buchholtz "*Surface Engineering using Ion Thruster Technology*," AIAA Paper 94-3235, Joint Propulsion Conference, June 1994, Indianapolis, IN.
- [5] McNally, J. "*Ion Assisted Deposition*," Handbook of Plasma Processing Technology, pp. 466-482, Noyes Pub., New Jersey, 1990.
- [6] Zheng, A. "*Optical Interference Filters: The Key in High Capacity Optical Systems*," *Fiberoptic Product News*, N. 10, pp. 18 – 24, 1999
- [7] Izawa, T., et. al., "*Ultra-low-loss multilayer reflectors and their applications*," *Japanese Journal of Applied Physics*, Vol. 62, No. 9, pp. 911-914, 1993.
- [8] Chen, F. F. Introduction to Plasma Physics and Controlled Fusion, V. 1, pp. 1-51, Plenum Press, New York, 1984.
- [9] Lieberman, M. A., A. J. Lichtenberg Principles of Plasma Discharges and Material Processing, pp. 1-124, John Wiley and Sons, New York, 1994.
- [10] Cecchi, J. L. "*Introduction to Plasma Concepts and Discharge Configurations*," Handbook of Plasma Processing Technology, pp. 14-69, Noyes Pub., New Jersey, 1990.

Installation Procedures for 3 cm



Caution

It is strongly recommended that extreme care be taken to avoid contamination of the ion source and its components.

All of the ion beam source sub-assemblies have been rigorously cleaned. Common vacuum practice is recommended while handling the source components. This requires that the operator use latex/or non-latex type gloves to prevent finger oil from contaminating the surfaces of the ion source. Eye protection should be worn at all times. Care should be taken to minimize particulate contamination such as hair and dust while the source is being assembled and installed.

The installation section is divided into:

- A. Identification of key source components and sub-assemblies.
- B. Attachment of the grids.
- C. Anode and cathode service.
- D. Source installation.
- E. Neutralizer installation.

Section A. 3 cm key components and sub-assemblies:

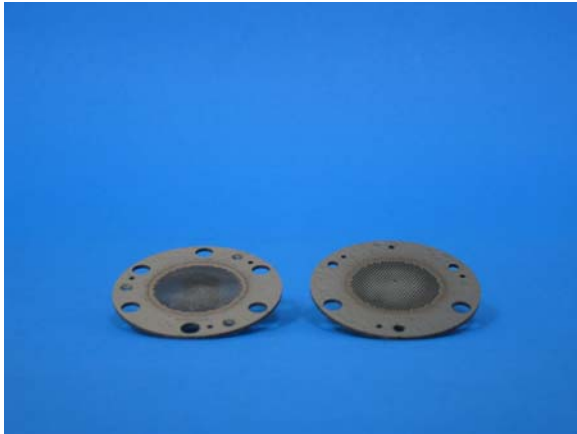

Picture 3.1 – Screen and accel grids.

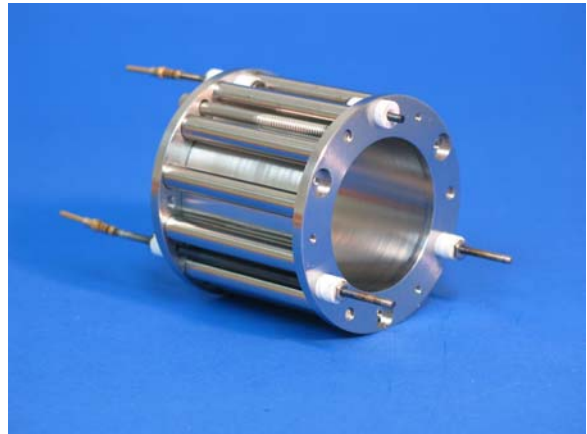

Picture 3.2 – Body assembly.



Picture 3.3 – Anode and cathode assembly.

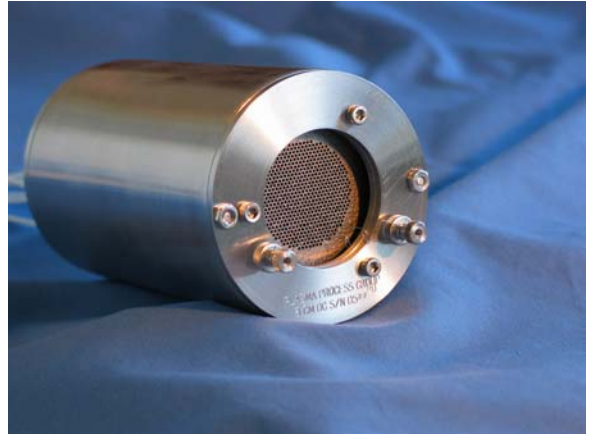

Picture 3.4 – Shroud



Picture 3.5 – Flange assembly.

Section B. 3 cm Grid assembly.

This section describes the installation of the grids onto the source body.

- 1) **CAUTION: THE GRIDS ARE FRAGILE.** The grid assembly requires delicate and deliberate movement. First, place insulators into the body locations as shown in Picture 3.6.

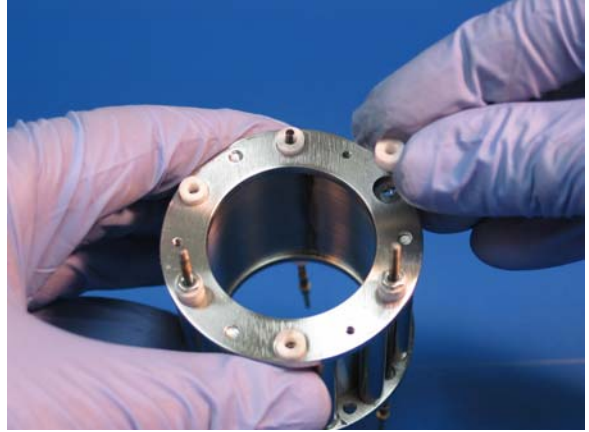

Picture 3.6 – Insulator placement

- 2) Next, place the screen grid on top of the body as shown in Picture 3.7. The screen grid has the relief (grid is thin in the center). The screen grid serial number should end with the letter “S”. Make sure the relief on the screen grid faces the body inside. Screen grid serial numbers are at the bottom and should be visible.

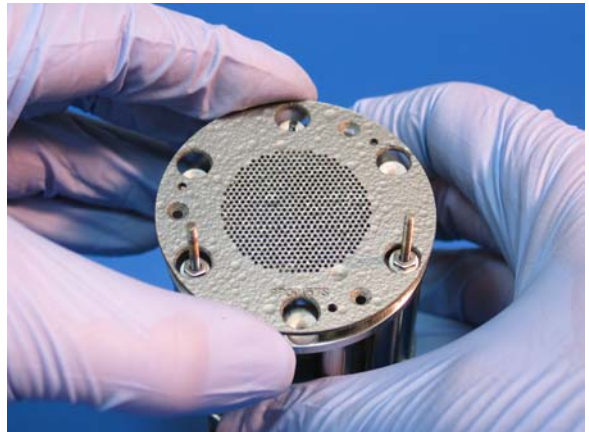

Picture 3.7 – Placement of the screen grid.

- 3) Secure the screen grid using the 2-56 screws as depicted in Picture 3.8. **CAUTION: Do not over tighten** as damage to the screen grid can occur.

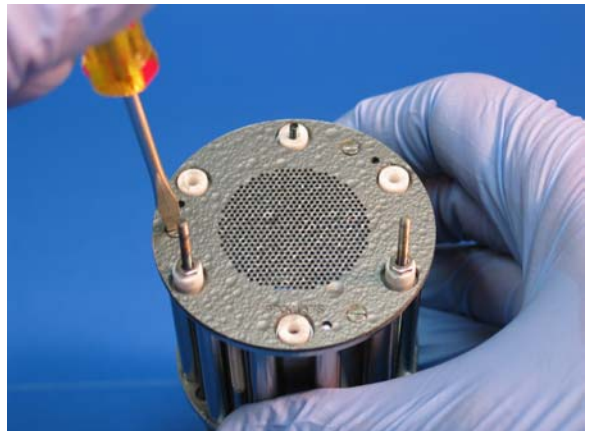

Picture 3.8 – Attachment of the screen grid.

- 4) Next, place the accel grid on top of the screen grid as shown in Picture 3.9. The accel grid should come in contact with the insulators, but it should not touch the screen grid. The serial number for the accel grid ends with the letter “A” and should be showing at the bottom. NOTE: The serial numbers can be used to orient the grids as they are engraved on the downstream side and bottom center of grid.

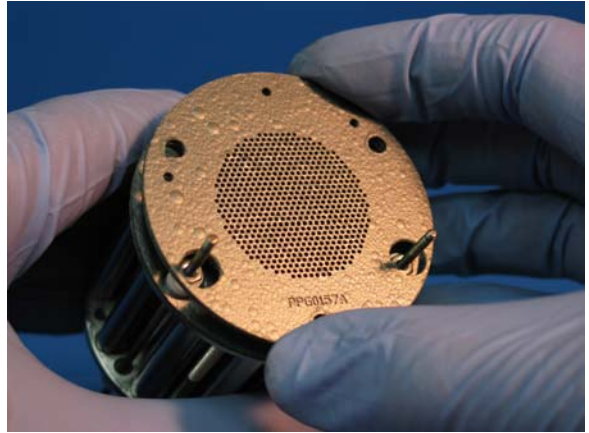

Picture 3.9 – Placement of the accel grid.

- 5) Insert the alignment pins into the grid alignment holes (Picture 3.10). The alignment pin should rest on the body.

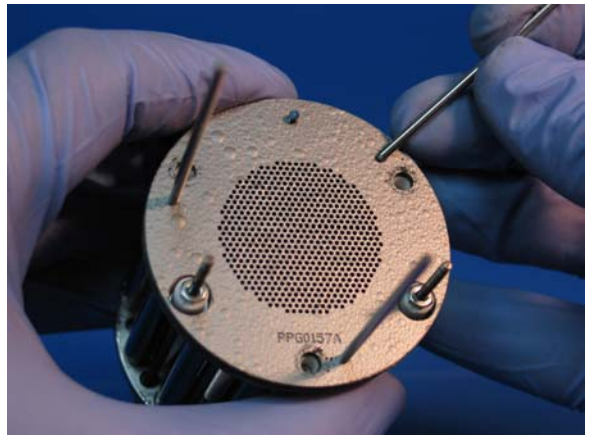

Picture 3.10 – Alignment pins inserted.

- 6) Secure the accel grid to the body using the 2-56 screw and insulator as shown in Picture 3.11. CAUTION: Care not to over-tighten as damage my result.

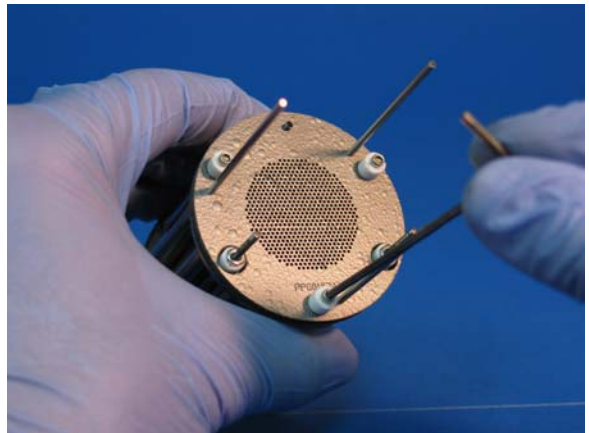

Picture 3.11 – Accel grid attachment.

- 7) Remove the alignment pins. Secure the accel grid electrical connection by fastening the 2-56 nut as shown in Picture 3.12. CAUTION: Careful not to over-tighten the nut as damage to the accel grid may occur.

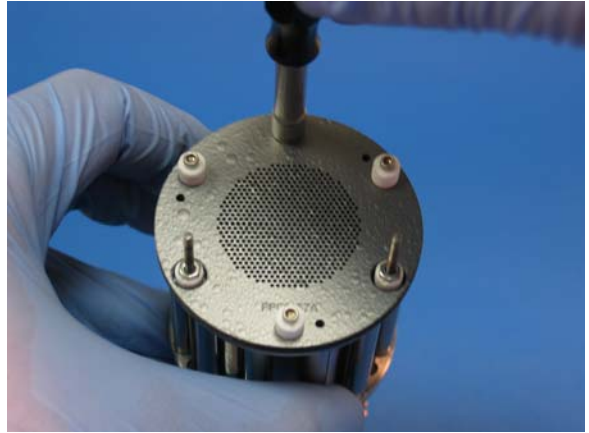

Picture 3.12 – Accel electrical connection.

- 8) The grids are now attached to the source body (Picture 3.13).

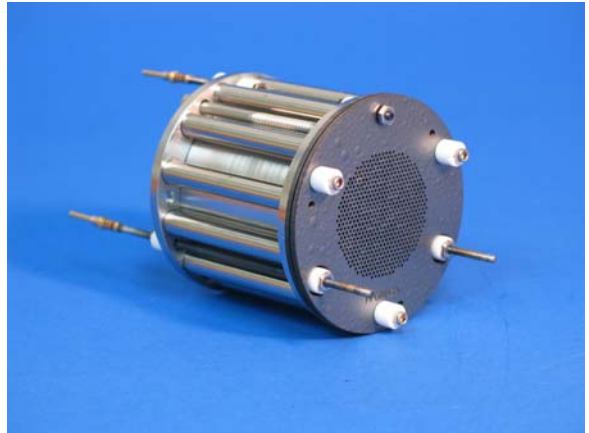

Picture 3.13 – Body with grids attached.

Section C. 3 cm Anode and Cathode Service.

This section describes the remove of the cathode and anode for service.

- 1) The anode and cathode can be serviced by removing the body back plate. The body back plate is referred to as the pole-piece mount plate. It is helpful to orientate the source so the accelerator electrical connection is at the top. CAUTION: If grids are attached to the body, do not place the grids on any surface which may induce damage.



Picture 3.14 – Back of body.

- 2) First, remove the 6-32 screws as depicted in Picture 3.15. There are 3 screws that secure the pole-piece mount plate.

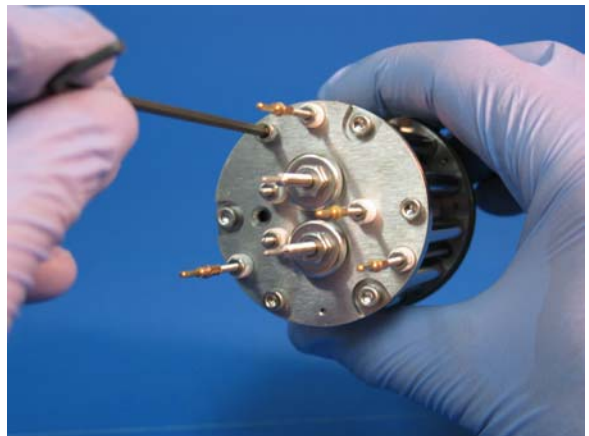

Picture 3.15 – Pole piece mount plate screws.

- 3) Gently slide the anode and cathode assembly out of the body. This is illustrated in Picture 3.16.



Picture 3.16- Removal of anode/cathode.

- 4) The anode and cathode assembly, shown in Picture 3.17, is now ready for service. Either the cathode filament can be replaced or the anode can be removed for cleaning.



Picture 3.17 – Anode and cathode assembly.

- 5) Replacement of the cathode is done by removing the two 6-32 screws (Picture 3.18). NOTE: It is important for proper source operation that ALL of the old cathode is removed completely. Filament debris may induce electrical shorting which will result in faulty operation of the source.

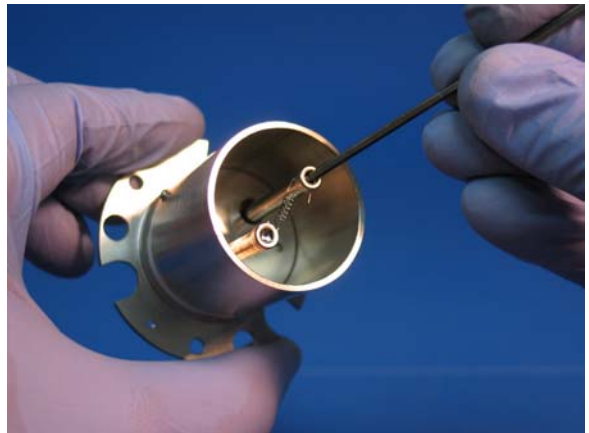

Picture 3.18 – Cathode installation / removal.

- 6) The anode is removed by loosening the 6-32 screws (Picture 3.19). NOTE: It is recommended the anode be cleaned periodically for proper source operation. Certain processes will create electrically conductive flakes on the anode. If these are not removed, they will induce electrical shorting and will result in faulty operation of the source.

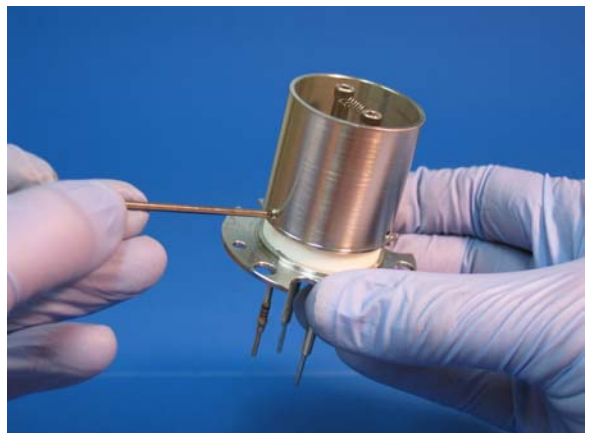

Picture 3.19 – Anode installation / removal.

Section D. Source Installation.

This section describes the installation of the source.

- 1) With the flange mounted to the vacuum system, insert the source assembly into the female receptacles as shown in Picture 3.20.

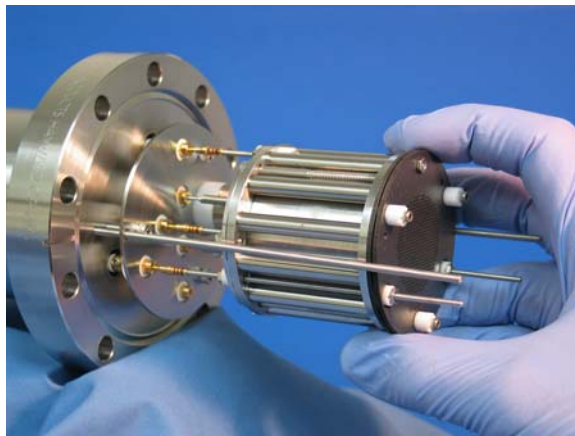

Picture 3.20 – Source assembly installation.

- 2) Next, slide the shroud over the source assembly (Picture 3.21). Align the neutralizer electrodes and make sure the grid insulators rest into the relief cuts on the shroud. The shroud should rest against the flange and the accelerator grid should not be in contact with the shroud.

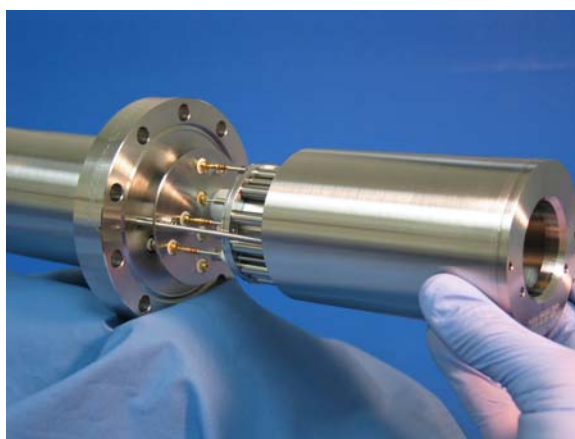

Picture 3.21 – Shroud installation.

- 3) Secure the shroud using the provided hardware. Also, install the insulators, cups, and 2-56 nuts for the neutralizer posts as depicted in Picture 3.22.

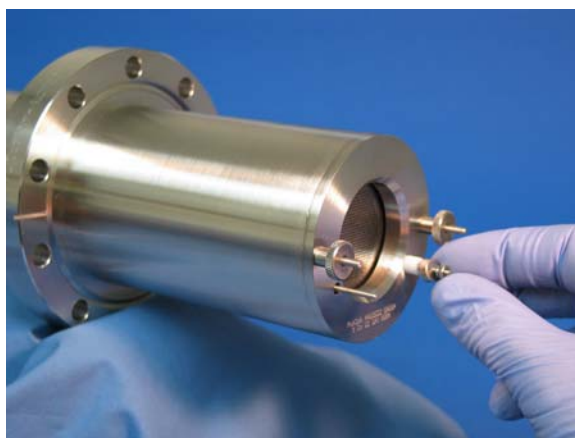

Picture 3.22- Final hardware installation.

Section E. Neutralizer Installation.

This section describes the installation of the neutralizer.

- 1) The filament neutralizer is attached to the neutralizer posts downstream from the source (see Picture 3.23). The neutralizer must be next to the center of the beam but should not cross the beam centerline (to maximize filament life). Also, if the neutralizer moves away from the beam, it may not effectively couple to the beam. The neutralizer must not touch the source shroud or damage to the power supply will result.

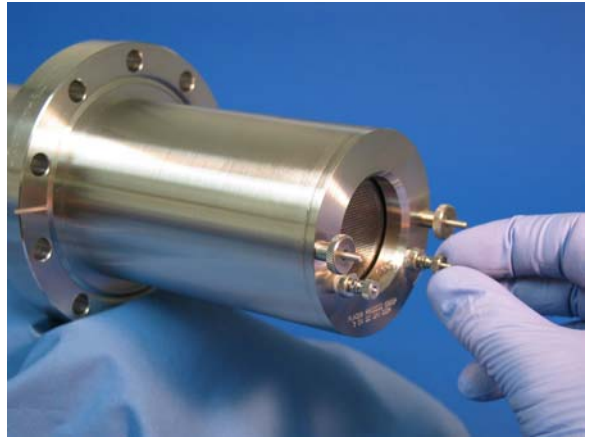

Picture 3.23 – Neutralizer installation.

Installation Procedures for 8 cm



Caution

It is strongly recommended that extreme care be taken to avoid contamination of the ion source and its components.

All of the ion beam source sub-assemblies have been rigorously cleaned. Common vacuum practice is recommended while handling the source components. This requires that the operator use latex/or non-latex type gloves to prevent finger oil from contaminating the surfaces of the ion source. Eye protection should be worn at all times. Care should be taken to minimize particulate contamination such as hair and dust while the source is being assembled and installed.

The installation section is divided into:

- A. Identification of key source components and sub-assemblies.
- B. Grid-mount assembly.
- C. Source assembly.
- D. Source and grid installation.
- E. Cathode and neutralizer installation.

Section A. Key source components and sub-assemblies:

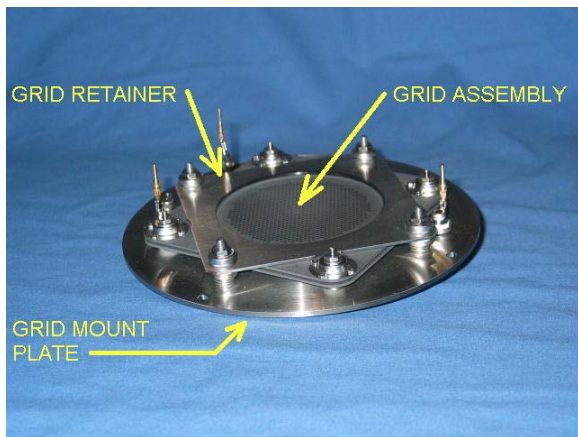

Picture 4.1 Grid mount assembly.



Picture 4.4 Shroud.

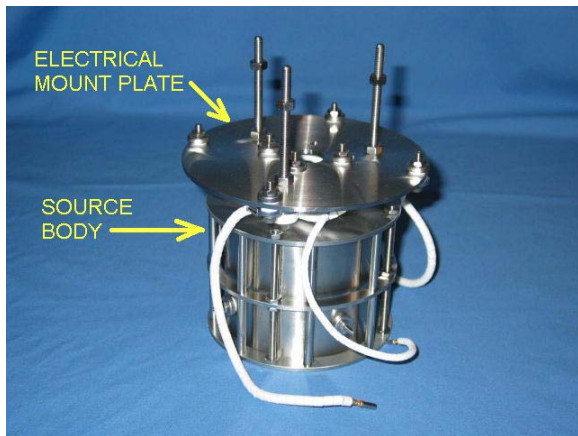

Picture 4.2 Electrical mount plate and body.

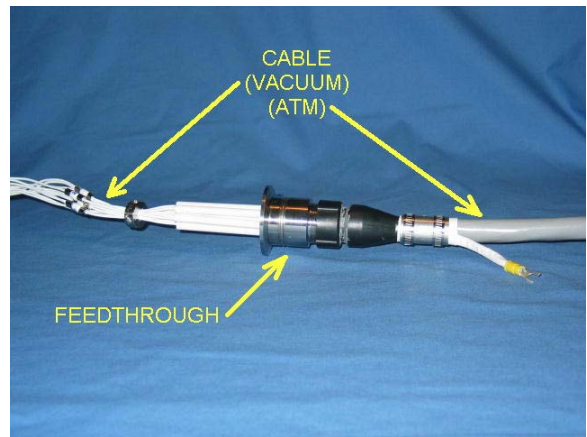

Picture 4.5 Electrical cable assembly.

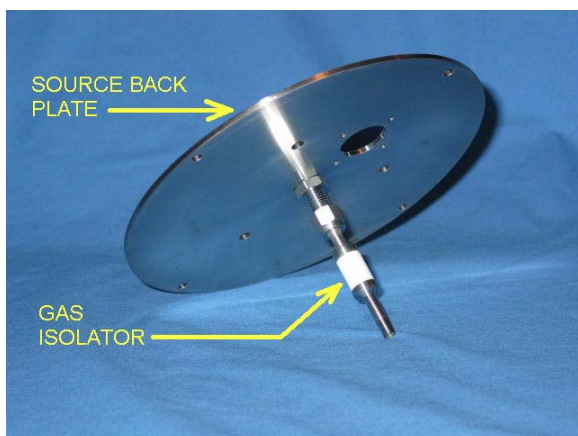

Picture 4.3 Back plate and gas isolator.

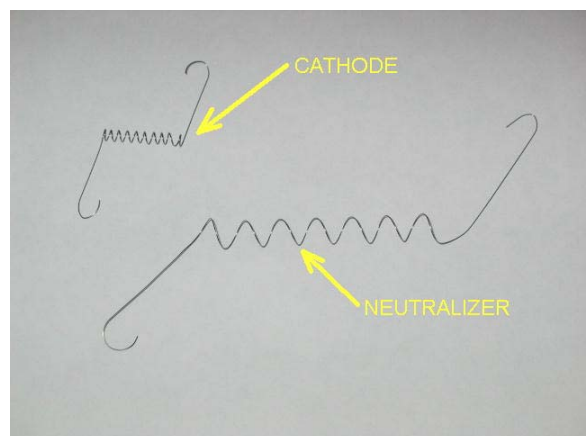

Picture 4.6 Cathode and Neutralizer.

Section B. Grid mount assembly.



Caution

It is strongly recommended that the grids be covered when work is being carried out on or near the ion source – to prevent damage by accidental contact. Disassembly of the grids should only be attempted by skilled personnel.

- 1) CAUTION: THE GRIDS ARE FRAGILE. The grid assembly requires delicate and deliberate movement. First, place the accelerator grid on a clean flat surface. Refer to drawing 504206 and build the insulator stack. See Picture 4.7.

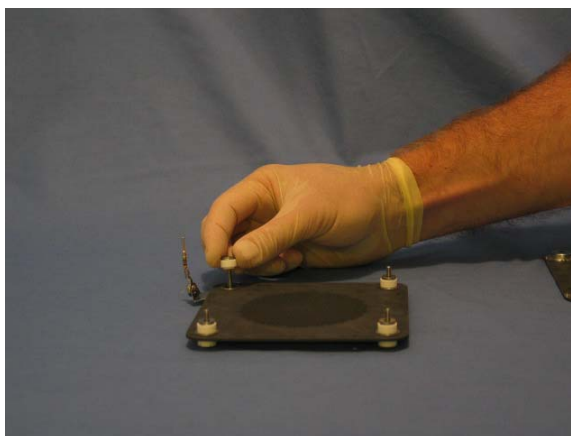

Picture 4.7. Accel grid being assembled.

- 2) Place the screen grid on top of the accelerator grid. Make sure to align the grid serial numbers face up. Refer to drawing 504206 for proper hardware placement on the assembly. See Picture 4.8.



Picture 4.8. Placement of screen grid.

Section B. Grid assembly (continued)

- 3) Next, insert the alignment pins through the holes provided. DO NOT FORCE. If the alignment pin does not insert easily, make sure all grid hardware is loose. See Picture 4.9.



Picture 4.9. Insert alignment pins.

- 4) Carefully tighten to a torque of 15 in-lb. each 6-32 nut (quantity 4) on the grid assembly. See Picture 4.10.

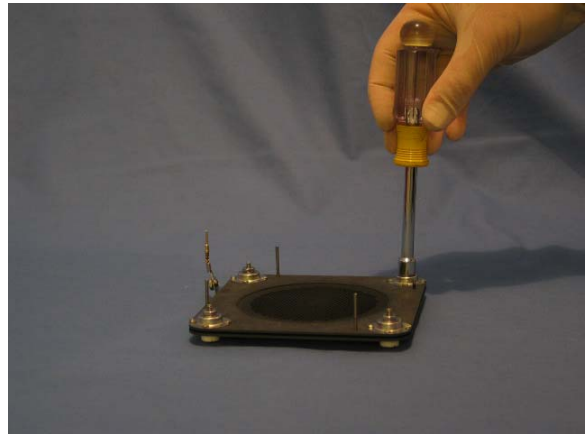

Picture 4.10. Grid assembly being tightened.

- 5) Carefully remove the alignment pins. See Picture 4.11.



Picture 4.11. Removal of alignment pins.

Section B. Grid assembly (continued).

- 6) Place the grid assembly onto the grid mount plate. See Picture 4.12. Refer to Chapter 7 for the grid mount plate hardware stacks and position of the accelerator electrical lead.



Picture 4.12. Placement of grid assembly onto grid mount plate.

- 7) Place the grid retainer over the grids. See Picture 4.13. Refer to Chapter 7 for description of the grid mount plate hardware stacks.

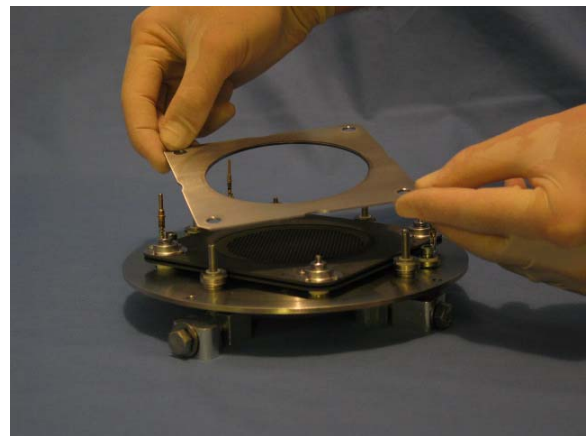

Picture 4.13. Installation of the grid retainer.

- 8) Secure the grid retainer plate with the 10-32 nuts (quantity 4) tightened to 15 in-lb torque. See Picture 4.14. The grid retainer should be rigid with respect to the grid mount plate. Also, the grid assembly should move independently of the retainer and mount plates.

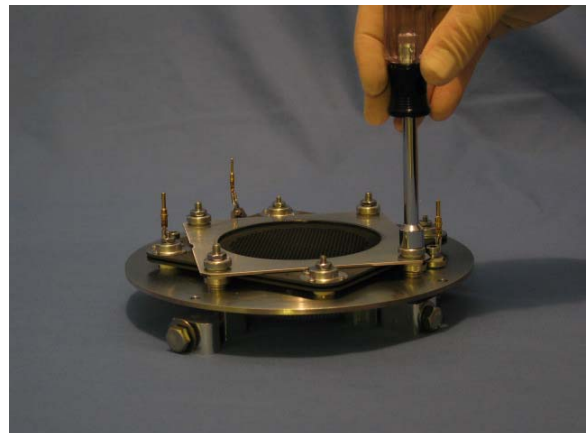

Picture 4.14. Securing the grid retainer.

Section B. Grid assembly (continued).

- 9) The grid mount assembly is now ready to be mounted into the source. See Picture 4.15.

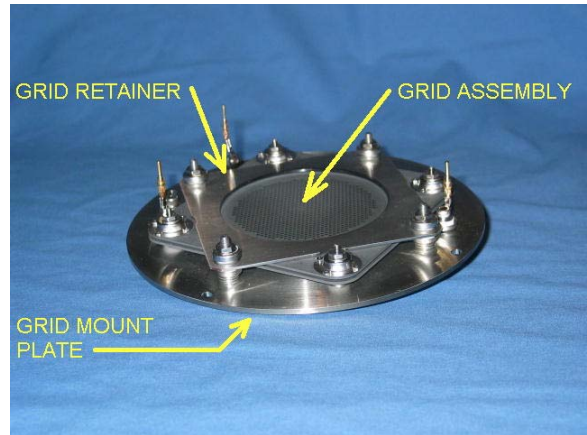

Picture 4.15. Grid mount assembly.

Section C. Source assembly.

- 1) Feed the vacuum side of the electrical cable through the source back plate. The #10 lugs need to be oriented such that they can be connected to the source body. See Picture 4.16.

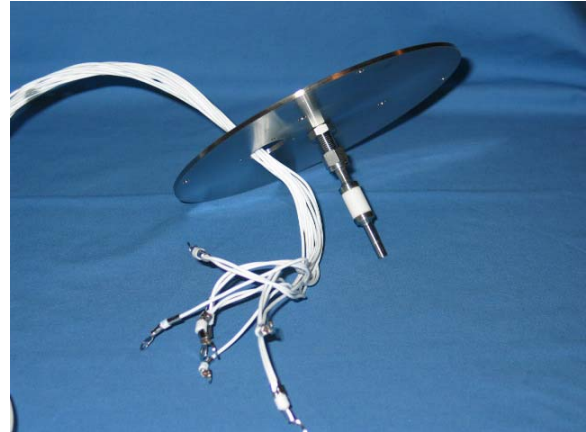

Picture 4.16. Electrical lead orientation.

- 2) Connect the electrical cable (vacuum side) to the electrical mount plate. Attach using 10-32 nuts at 15 in-lb torque. See Picture 4.17. The electrical connections are numbered in the following sequence:

| LEAD NUMBER | DESCRIPTION |
|-------------|----------------------|
| 1 | Cathode Filament |
| 2 | Body |
| 3 | Anode |
| 4 | Cathode Filament |
| 5 | Accel |
| 6 | Neutralizer Filament |
| 7 | Neutralizer Filament |



Picture 4.17. Attachment of cable

- 3) Insert source back plate onto the source body. Check to ensure that electrical leads are clear of the gas isolator. The gas isolator should slide into the top of the source body. See Picture 4.18.



Picture 4.18. Attachment of source back plate.

Section C. Source assembly (continued).

- 4) Attach the source back plate to the body using $\frac{1}{4}$ -20 nuts (quantity of 3). See Picture 4.19.



Picture 4.19. Attachment of back plate.

- 5) Attach the electrical lead cover to the back plate using 6-32 screws (quantity of 2). The cables can be oriented in any direction. See Picture 4.20.



Picture 4.20. Attachment of cable cover

- 6) Attach the source shroud by placing the body/back plate assembly into the shroud. See Picture 4.21.



Picture 4.21. Insert body into the shroud.

Section C. Source assembly (continued).

- 7) Secure the source back plate to the shroud by using 10-32 screws (quantity 4). See Picture 4.22.



Picture 4.22. Back plate attachment.

- 8) Connect the required gas line to the source back plate. See Picture 4.23. The source is now ready for installation into the vacuum system.



Picture 4.23. Gas line connection

Section D. Source Installation.

- 1) Using the mount hardware on the source back plate, attach the source to the appropriate mounting hardware in the vacuum system. See Picture 4.24. After the source is mounted, check proper installation of the cathode has been performed (refer to Section E).



Picture 4.24. Attaching the source to the vacuum chamber.

- 2) Identify the electrical leads attached to the source (see Picture 4.25):
 - a. Accelerator lead connection. This is the No. 16 Socket (small).
 - b. Neutralizer lead connections. These are the No. 12 Sockets (large).



Picture 4.25. Electrical leads.

- 3) Attached the electrical leads to the grid mount assembly. See Picture 4.26. Carefully place the grid mount plate against the shroud so that its connection holes are aligned. Make sure the electrical leads remain inside the shroud.



Picture 4.26. Electrical lead attachment.

Section D. Source Installation (continued).

- 4) Secure the grid mount assembly to the shroud using 10-32 screws (quantity 4). See Picture 4.27.



Picture 4.27. Attachment of the grid mount assembly.

- 5) Install the Filament Neutralizer. See Picture 4.28. The filament neutralizer can be installed by tightening its mounting hardware. CAUTION: older neutralizers are brittle and may fracture upon removal. Small fractures can be sharp and may induce electrical shorting of other components.



Picture 4.28. Neutralizer installation.

- 6) Attached the gas line from the source to the feedthrough. See Picture 4.29.

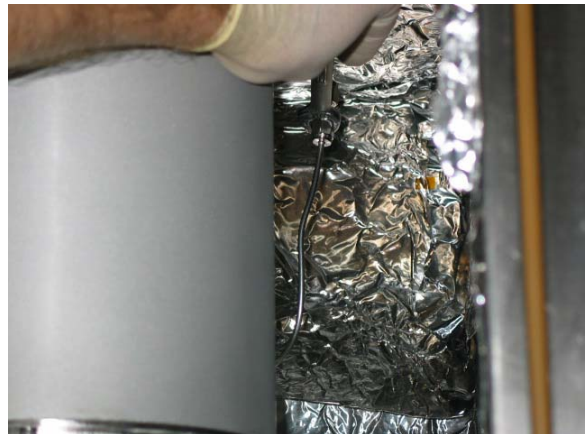

Picture 4.29. Gas line attachment.

Section D. Source Installation (continued).

- 7) Study the following diagram for the electrical feedthrough. The pin numbers need to match the electrical lead numbers. See Diagram D-1.

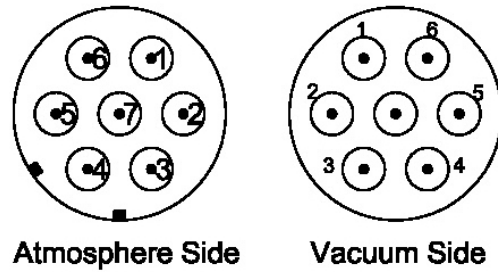
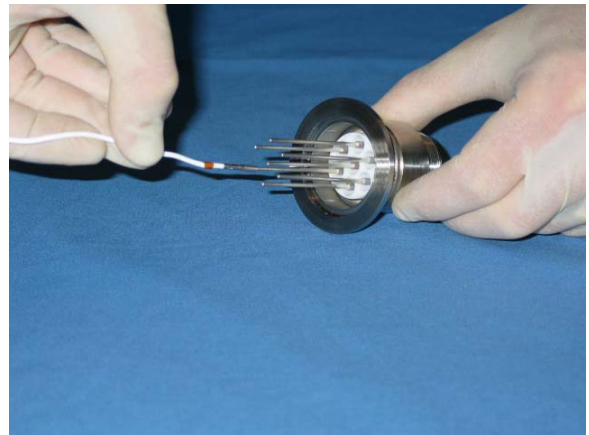

Diagram D-1. Feedthrough pin numbers.

- 8) Connect the individual leads of the vacuum side of the electrical cable to the electrical feedthrough. See Picture 4.30. Be sure to match the pin numbers in Diagram D-1.



Picture 4.30. Electrical lead connection.

- 9) **CAUTION: MAKE SURE THE ELECTRICAL GROUND LEAD ON THE ATMOSPHERIC SIDE IS ATTACHED TO THE VACUUM CHAMBER.** See Picture 4.31.

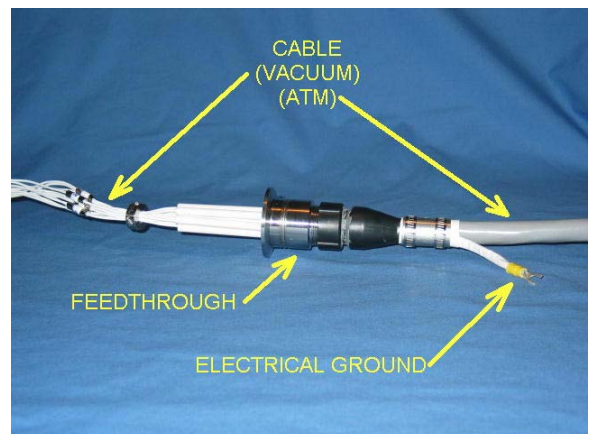

Picture 4.31. Electrical cable arrangement.

Section D. Source Installation (continued).

10) It is recommended to cover the electrical leads using vacuum foil. See Picture 4.32.



Picture 4.32. Protection of electrical leads.

11) Before operation of the source, it is recommended that a target be placed downstream. See Picture 4.33. The ion beam source is now ready for operation.



Picture 4.33. Ion beam source and target.

Section E. Cathode and Neutralizer **Installation/Removal.**

- 1) The grid assembly must first be removed to access the cathode. The filament cathode can be installed or removed by tightening or loosening its hardware inside the source body. See Picture 4.34. Caution: older cathodes are brittle and may fracture upon removal. Small fractures can be sharp and may induce electrical shorting of other components.

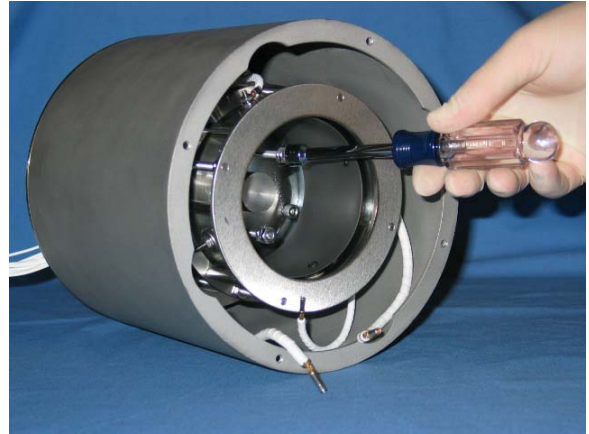

Picture 4.34. Cathode installation/removal.

- 2) The filament neutralizer can be installed or removed by tightening or loosening its mounting hardware. See Picture 4.35. Caution: older neutralizers are brittle and may fracture upon removal. Small fractures can be sharp and may induce electrical shorting of other components.



Picture 4.35. Neutralizer installation/removal.

Operation

With the ion beam source installed in the vacuum chamber as described in the previous section, it is now ready for operation. This section will describe proper operation of the source. Actual operating values are attached in Appendix B.

Step 1) **Pumpdown.**

The ion beam source requires a high vacuum environment for proper operation. As there are several different types of vacuum systems, general guidelines will be presented. Also, the vacuum environment will depend upon the application for the ion beam source. The required pumping speed of the vacuum system will depend upon how much process gas is used by the ion beam source and the vacuum environment required for the process. Problems may arise with operation of the ion beam at higher pressures. Presented in Table 5.1 are general vacuum specifications guidelines.

Table 5.1. Vacuum specifications.

| Specification | Value | Comments |
|---|-----------------------------|--|
| Chamber base pressure | 10^{-6} Torr | Lower is OK |
| Chamber operating pressure when the source gas is on. | 10^{-5} to 10^{-3} Torr | The discharge may go out at lower pressures. Grid arcing will occur at higher pressures. |
| Typical pumping speed | 1000 l/s (air) | Process dependent. |

Step 2) **Turn the process gas on.**

After the vacuum chamber has achieved its base pressure, turn on the process gas. The amount of gas is typically measured in standard cubic centimeters per minute, or sccm. The required amount can be selected based upon the application. Actual gas flow settings are presented in Appendix B. It is recommended to wait 5 to 10 minutes after the gas has been turned on in order

to purge the gas line. Recommended flow rates for a system using a 1000 l/s pump are presented in Table 5.2.

Table 5.2. Typical source gas flow rates for a 1000 l/s pumping station.

| Specification | Value | Comment |
|----------------------|--------------------|---------------------|
| 3 cm Source gas flow | 3 to 6 sccm Argon | Typical flow range. |
| 8 cm Source gas flow | 5 to 10 sccm Argon | Typical flow range. |

Step 3) **Turn on the water cooling.**

If the source has water cooling, turn it on at this time. The water cooling must have a flow switch connected to the interlock string. If the source cooling stops flowing, the power supply output will shut off.

Step 4) **Turn the source on and allow it to warm-up.**

| | |
|---|--|
|  | <p>Warning</p> <p>Danger of High Voltage and Personnel Injury</p> |
|---|--|

CAUTION: Make sure all electrical connections have been properly made and that the power supply interlock has been satisfied.

Turn the power supply on.

Set the cathode current and discharge voltage to the recommending starting conditions in Table 5.3. Similarly, adjust the neutralizer starting current.

Table 5.3. Recommending starting cathode current, discharge voltage and neutralizer current.

| Source | Cathode heater I (A) | Discharge V (V) | Neutralizer heater I (A) |
|-------------|----------------------|-----------------|--------------------------|
| 3 cm Source | 3 | 40 | 3 |
| 8 cm Source | 4 | 55 | 4 |

Turn on the source by pressing the SOURCE button. When the SOURCE button is pressed, the power supply will begin to apply power to the cathode, discharge and neutralizer. The

cathode and neutralizer heaters will ramp to their respective set point (or last setting). The discharge voltage will ramp to an ignition voltage that is typically higher than 150V. As soon as a discharge starts, the discharge voltage will ramp to its starting set point.

An established plasma discharge is indicated when the discharge current is detected. A reasonable discharge current range for source warm up is 0.5 to 0.7 A. If the discharge current is not within this range, increase or decrease the cathode heater current appropriately.

The recommended warm up period is 10 minutes. If the neutralizer current is sufficient, an emission current will be present. As the source heats it may release trapped water vapor gases which may result in a temporary increase in chamber pressure. Presented in Table 5.4 are typical source warm up conditions. If the discharge current cannot be established, is excessively high, or other starting issues arise, please refer to Chapter 6 - Troubleshooting.

Table 5.4. Typical warm up data.

| Source | Gas | Pressure | Cathode | Discharge | | Beam | | Accelerator | | Neutralizer | |
|--------|-----------|------------------|---------|-----------|-----|------|-----|-------------|-----|-------------|----------|
| | | $\times 10^{-4}$ | Heater | I | V | I | V | I | V | Heater | Emission |
| | | (Torr) | (A) | (A) | (V) | (mA) | (V) | (mA) | (V) | (A) | (mA) |
| 3 cm | 4 sccm Ar | 2.2 | 3.5 | 0.75 | 40 | 0 | 0 | 0 | 0 | 4.0 | 50 |
| 8 cm | 5 sccm Ar | 2.6 | 4.5 | 0.70 | 55 | 0 | 0 | 0 | 0 | 4.0 | 30 |

Step 4) **Set the beam conditions and turn the beam on.**

Set the beam and accelerator voltage for the desired condition. Optimized beam and accelerator voltages will be specific for a given process. Recommended conditions for typical applications are presented in Table 5.5. The comments in Table 5.5 are for standard grids. Grids can be customized for ion beam directional control.

Table 5.5. Typical beam and accelerator voltage settings.

| Application | Beam V | Accel V | Comments |
|--------------------------------|--------|---------|---------------------|
| Low energy etch or assist beam | 300 V | 700 V | Beam is spread out. |
| Low rate sputtering | 750 V | 300 V | Beam is mid sized. |
| High rate sputtering | 1250 V | 250 V | Beam is focused. |

Next, select how the beam current will be controlled. There are three modes of control for the beam current. These are MANUAL, LOCAL and REMOTE. In order to select which mode to run press the MODE button. A description of these modes is listed in Table 5.6. For troubleshooting source problems, MANUAL mode is recommended. For most applications, LOCAL mode is useful for running a process.

Table 5.6. Definition of the power supply operational MODES.

| | |
|--------|---|
| MANUAL | The operator can adjust the cathode current for beam current control. |
| LOCAL | The operator selects a beam current and the power supply regulates cathode current. |
| REMOTE | Same as LOCAL, except that a computer is controlling the power supply. |

If MANUAL MODE is selected, when the BEAM button is pressed, the extracted beam current is determined by the given discharge conditions. Beam current is increased or decreased by adjusting the cathode heater current.

If the LOCAL mode is selected, a target value for beam current can be set in the BEAM module. When the BEAM button is pressed, the power supply will regulate the discharge current by adjusting the cathode heater to extract the target beam current.

Step 5) **Adjusting the beam conditions.**

The beam current and voltage can be adjusted while the beam is on. However, for some conditions, the beam may need to be turned off while keeping the source on. Also, switching between MANUAL and LOCAL power supply modes may be necessary to achieve desired beam conditions. Also, some beam currents may not be achievable at various beam voltages (e.g. high beam current at low beam voltage). Please consult Chapter 8 Appendix B for the nominal range of beam currents and voltages.

Additional recommendations for setting the beam current include start the source with a lower cathode heater current (i.e. lower discharge current) and a higher accelerator voltage. If there are issues with the beam current and voltage please consult Chapter 6 - Troubleshooting.

Step 6) **Optimizing the accelerator voltage.**

For some applications it can be useful to optimize the accelerator voltage. If the application requires low beam voltage (i.e. low ion energy) the accelerator voltage is usually required to be high and the beam spreads out as it leaves the source. On the other hand, if the application requires higher beam voltage (i.e. high ion energy), the accelerator voltage can be optimized to improve the accelerator grid life.

After a beam current and voltage are selected, start with a high accelerator voltage. Put the power supply in MANUAL mode. Decrease the accelerator voltage and examine the accelerator

current and discharge current. When the discharge current begins to increase, electrons will begin to back-stream. At this condition, the accelerator voltage is too low. The accelerator voltage is optimized by increasing it above this setting by 50 to 75 V. Illustrated in Table 5.7 is an example of optimizing the accelerator voltage at a given beam condition.

Table 5.7. Electron back-streaming occurs at an accelerator voltage of 50 V. Optimized is 100V.

| Source | Gas | Pressure | Cathode | Discharge | | Beam | | Accelerator | | Neutralizer | |
|--------|-----------|------------------|---------|-----------|-----|------|------|-------------|-----|-------------|----------|
| | | $\times 10^{-4}$ | Heater | I | V | I | V | I | V | Heater | Emission |
| | | (Torr) | (A) | (A) | (V) | (mA) | (V) | (mA) | (V) | (A) | (mA) |
| 8 cm | 5 sccm Ar | 2.6 | 3.96 | 0.33 | 55 | 100 | 1250 | 5 | 150 | 3.6 | 125 |
| | 5 sccm Ar | 2.6 | 3.96 | 0.33 | 55 | 100 | 1250 | 4 | 100 | 3.6 | 125 |
| | 5 sccm Ar | 2.6 | 3.96 | 0.33 | 55 | 100 | 1250 | 4 | 75 | 3.6 | 125 |
| | 5 sccm Ar | 2.6 | 3.96 | 0.35 | 55 | 110 | 1250 | 4 | 50 | 3.6 | 125 |

The A/B ratio in the power supply may require adjustment. The A/B ratio is the accelerator to beam current ratio. The ratio is entered into the power supply and will induce an alarm if the A/B ratio is exceeded. A typical A/B ratio is 10% and at this condition, the power supply will alarm if the accelerator current is greater than 10% of the beam current.

Step 8) **Neutralizer operation.**

When the BEAM button is pressed, the neutralizer emission current should increase. If the power supply is in MANUAL mode, the emission current is determined by the given neutralizer heater current. If the power supply is in LOCAL mode, the emission current will adjust to the E/B ratio. The E/B ratio is emission current to beam current ratio. For typical applications, E/B is set to 125% or greater. At this condition, the emission of electrons from the neutralizer is more than the beam current. This will assist with the downstream conditions and minimize surface charging and arcing.

Step 9) **Turning the source off and cool down.**

The beam and source are shut off by pressing the source button. The power supply can be then turned off. It is recommended to leave the process gas running while the source cools for

10 minutes. It is recommended cooling the source about 20 minutes before the vacuum chamber is vented.

Step 10) **Maintenance.**

Depending upon the process environment for the source, the maintenance times may vary. Presented in Table 5.8 are normal maintenance items. If oxygen is used, the filament life is about 50% of those listed in Table 5.8. If methane is used, the grid, anode and insulator cleaning are 50% less than those listed.

Table 5.8. Maintenance items.

| Specification | Value | Comment |
|---------------------------|----------------|--|
| Cathode Filament Life | 30 to 50 hours | Higher discharge voltage will reduce life. |
| Neutralizer Filament Life | 5 to 30 hours | Higher beam power will reduce life. |
| Grid cleaning | 200-500 hours | Process dependent. |
| Anode cleaning | 200-700 hours | Process dependent. |
| Insulator cleaning | 500-1000 hours | Process dependent. |
| Magnet replacement | +3000 hours | Process dependent. |

Replacement parts can be purchased from Plasma Process Group, Inc.

In order to clean the grids, they must be disassembled. Emery paper can be used to remove material on the accelerator grid. The grids must be thoroughly cleaned before reassembly as any debris may induce arcing between the grids. The grids should be ultrasonically cleaned in water and Mirco-90 solution, thoroughly baked, wiped with alcohol and blown with dry nitrogen before reassembly.

The anode and source insulators can be bead-blast cleaned. The bead-blast media should be 150 grit, alumina and delivered at pressures of 40 psi or less. The hardware should then be ultrasonically cleaned, followed by an acetone wipe/rinse and a final alcohol wipe/rinse.

Troubleshooting

As there are many variables with the ion beam source, the troubleshooting is divided into the various stages of operation. First, common issues with the power supply are presented. It is important to be aware of the electrical nature of the ion beam source. Most issues arise from electrical shorting or openings that disrupt proper operation. These issues may not present themselves easily, say with a multi-meter, as it may be a plasma short or a thermal open that creates the issue.

This chapter is divided into:

Power Supply – Problems that are detected by the power supply.

Starting the source – Cathode, anode and discharge problems.

Turning the beam on – Beam, accelerator, and grid problems.

Neutralizer operation – Neutralizer problems.

Special diagnostics and testing.

Power Supply

Table 6.1 Problems as detected by the power supply.

| Error | Description | Possible problems and solutions |
|-------|--|--|
| 03 | Output of module is lower than requested. | <ol style="list-style-type: none"> 1. Facility voltage is too low – Check facility voltage. 2. Electrical connection is poor – Check electrical connections 3. Power supply fuse has failed – Check fuses. |
| 04 | Output of module is higher than requested. | <ol style="list-style-type: none"> 1. Electrical short – Check electrical connections. 2. Plasma short – Check the source and feedthru for electrical wire proximity problems or coated insulators. 3. Gas flow is too high – Check gas flow level. |
| 05 | Module is in current limit. | <ol style="list-style-type: none"> 1. Electrical short – Check electrical connections. 2. Plasma short – Check the source and feedthru for wire proximity problems or coated insulators. 3. Electrical short – Check for flakes or debris. |
| 06 | Module is at over temperature. | <ol style="list-style-type: none"> 1. Cooling issue – Make sure fan is operational and unobstructed. 2. Dust buildup – Clean any dust buildup on power supply. |
| 10 | Heater current is greater than max heater current set point. | <ol style="list-style-type: none"> 1. Filament is too long – Replace filament or adjust software limit. |
| 20 | Interlock is open | <ol style="list-style-type: none"> 1. Water flow – Check water flow. 2. Vacuum – Check vacuum interlock. 3. Interlock cable is not connected – Check cable and connections. |
| 22 | Cathode filament error | <ol style="list-style-type: none"> 1. Filament failure (filament open) – Replace filament. 2. Cable is not connected – Check cable and feedthru connections. |
| 23 | Neutralizer filament error | <ol style="list-style-type: none"> 1. Filament failure (filament open) – Replace filament. 2. Cable is not connected – Check cable and feedthru connections. |
| 24 | E/B Ratio (emission current to beam current ratio) | <ol style="list-style-type: none"> 1. Emission current too low – Check neutralizer filament. 2. Neutralizer location – Neutralizer is too far from beam. 3. Filament is too long – Replace filament. 4. Leakage current on neutralizer insulators – Clean / replace insulators. |
| 25 | A / B Ratio (accel current to beam current ratio) | <ol style="list-style-type: none"> 1. Accel current is too high – Check alignment of grids. 2. Accel voltage is too low – Increase accel voltage. 3. Unstable beam condition – Examine data provided with source. 4. Grid spacing incorrect – Check grid spacing. 5. Debris between the grids – Clean and inspect the grids. 6. Leakage current on grid insulators – Clean / replace insulators. |

Starting the Source

Table 6.2 Problems with CATHODE, ANODE and DISCHARGE.

| Problem description | Possible problems and solutions |
|---|---|
| Cathode filament current is zero | <ol style="list-style-type: none"> 1. Filament failure – Check and replace filament 2. Faulty connection – Check cable and feedthru connections (Table 6.5). 3. Possible power supply problem – Have power supply serviced. |
| Cathode filament current lower than normal | <ol style="list-style-type: none"> 1. Faulty connection – Check cable and feedthru connections (Table 6.5). 2. Cathode filament is smaller than standard size. 3. Cathode filament is older than a newer one. |
| Cathode filament current higher than normal | <ol style="list-style-type: none"> 1. Cathode is electrically shorted – Check electrical connections in cable, feedthru and source. 2. Cathode filament is longer than standard size. 3. Cathode filament is a newer one. |
| Discharge current is zero. | <ol style="list-style-type: none"> 1. Discharge has not started – Check gas flow rate, make sure flow is OK. 2. Discharge has not started – Check gas flow connection. 3. Discharge has not started – Check status of the cathode operation. 4. Faulty electrical connection – Check cable and feedthru connections. 5. Faulty electrical connection – Check anode electrical connections. 6. Failed body fuse – Check body fuse. |
| Discharge current lower than normal | <ol style="list-style-type: none"> 1. Anode has a poor connection – Check anode electrical connections. 2. Anode is coated / insulated – Clean anode 3. Cathode is older than a newer one. 4. Gas flow is lower than expected – Check gas flow operation. |
| Discharge current higher than normal | <ol style="list-style-type: none"> 1. Anode has shorted to the body – Check anode and body connections, look for debris or flakes, clean where necessary. 2. Anode insulator is coated – Check anode insulator and clean / replace. 3. Gas flow is higher than expected – Check gas flow operation. |

Turning on the Beam

Table 6.3 Problems with BEAM and ACCEL.

| Problem description | Possible problems and solutions |
|----------------------------------|---|
| Beam current zero. | <ol style="list-style-type: none"> 1. Discharge is not started or is out – Check discharge operation (Table 6.2) 2. Faulty connection – Check cable and feedthru connections (Table 6.5). 3. Possible power supply problem – Have power supply serviced. |
| Beam current lower than normal | <ol style="list-style-type: none"> 1. Gas flow is lower than expected – Check gas flow and operation. 2. Discharge current is too low – Check discharge operation (Table 6.2) 3. Cathode is newer than an older one (Manual mode). |
| Beam current higher than normal | <ol style="list-style-type: none"> 1. Screen grid is electrically shorted – Check body electrical connections. Look for signs of plasma shorts, coated insulators and electrical lead wire proximity issues. 2. If both accel and beam current are high - Check the grid alignment and spacing. Check for accel to screen grid shorting (Table 6.5) 3. Anode is electrically shorted – Check anode connections. Look for signs of plasma shorts inside source, coated insulators and electrical lead wire proximity issues. 4. Screen grid has debris or flakes – Clean screen grid. 5. Discharge current is too high – Check discharge operation (Table 6.2). 6. Gas flow is higher than expected – Check gas flow and operation. 7. Cathode is older than a newer one (Manual mode). |
| Accel current zero. | <ol style="list-style-type: none"> 1. Discharge not started or is out – Check discharge operation (Table 6.2) 2. Faulty connection – Check cable and feedthru connections (Table 6.5). 3. Possible power supply problem – Have power supply serviced. |
| Accel current lower than normal | <ol style="list-style-type: none"> 1. Accel grid has a faulty electrical connection – Check connections. 2. Gas flow is lower than expected – Check gas flow operation. |
| Accel current higher than normal | <ol style="list-style-type: none"> 1. Accel grid is electrically shorted – Check accel electrical connections. Look for signs of plasma shorts inside the source, coated insulators and electrical lead wire proximity issues. 2. If both accel and beam current are high - Check the grid alignment and spacing. Check for accel to screen grid shorting (Table 6.5) 3. Accel grid insulators are coated – Check insulators and clean / replace. 4. Accel grid insulators are coated – Perform high-pot test (Table 6.5). 5. Gas flow is higher than expected – Check gas flow operation. 6. Beam voltage is too low – Examine the source run data. |
| Arcing | <ol style="list-style-type: none"> 1. Debris or flakes are in proximity to the grids – Check and clean the screen and accel grid. 2. Accel grid is coated with dielectric material – Clean the accel grid. 3. Grids have contamination – Clean grids ultrasonically in Micro-90 and water. Rinse and wipe with alcohol. Bake grids under a heat lamp to remove water vapor. Wipe with alcohol and blow with dry nitrogen. 4. Source was not warmed up long enough – increase warm up time. |

Neutralizer Operation

Table 6.5 Problems with the neutralizer.

| Problem description | Possible problems and solutions |
|---|--|
| Neutralizer filament current is zero | <ol style="list-style-type: none"> 1. Filament failure – Check and replace filament 2. Faulty connection – Check cable and feedthru connections (Table 6.5). 3. Possible power supply problem – Have power supply serviced. |
| Neutralizer filament current lower than normal | <ol style="list-style-type: none"> 1. Faulty connection – Check cable and feedthru connections (Table 6.5). 2. Filament is smaller than standard size. 3. Filament is older than a newer one. |
| Neutralizer filament current higher than normal | <ol style="list-style-type: none"> 1. Neutralizer is electrically shorted – Check electrical connections in cable, feedthru and source. 2. Filament is longer than standard size. 3. Filament is a newer one. |
| Emission current is zero | <ol style="list-style-type: none"> 1. Neutralizer filament is not close to beam – move filament. 2. Filament current is too low – Examine run data for the source. 3. Source gas is off or low – check source gas operation. 4. Neutralizer is electrically shorted – Check cable (Table 6.5). 5. Faulty connection – Check cable and feedthru connections (Table 6.5). 6. Failed emission fuse – Check emission fuse. |
| Emission current is lower than expected | <ol style="list-style-type: none"> 1. Filament current is too low – Increase filament current (Manual mode). 2. E/B ratio is set incorrectly – Check the E/B ratio (Local mode). |
| Emission current is higher than expected | <ol style="list-style-type: none"> 1. Filament current is too high – Lower filament current (Manual mode). 2. E/B ratio is set incorrectly – Check the E/B ratio (Local mode) |
| Emission current is unstable | <ol style="list-style-type: none"> 1. Filament cannot effectively couple to the beam – Move filament closer to the beam. 2. Filament is too long. |

Special Testing

Table 6.5 Diagnostics and testing procedures.

| Problem description | Possible problems and solutions |
|---|---|
| Cathode filament current is zero or lower than normal. | 1. Faulty connection – Check cable and feedthru connections. Note: With the source off, disconnect the source cable from the power supply. Use an ohm meter and measure the resistance between pins A/D and G/E. The reading should be 2 ohms or less to indicate the filament is intact and properly connected. |
| Beam current zero. | 1. Faulty connection – Check cable and feedthru connections. Note: With the source off and at atmosphere, disconnect the source cable from the power supply. Use an ohm meter and measure the resistance between pin C and the anode. The reading should be 2 ohms or less to indicate the anode is properly connected. |
| Accel current zero. | 1. Faulty connection – Check cable and feedthru connections. Note: With the source off and at atmosphere, disconnect the source cable from the power supply. Use an ohm meter and measure the resistance between pin F and the accelerator grid. The reading should be 2 ohms or less to indicate the accel grid is properly connected. |
| Beam current and Accel current higher than normal | 1. Check for accel to screen grid shorting. Note: With the source off and at atmosphere, disconnect the source cable from the power supply. Use an ohm meter and measure the resistance between pin B and pin F. The reading should be open to indicate the body (screen grid) is not shorted to the accel grid. |
| Neutralizer filament current is zero or lower than normal | 1. Faulty connection – Check cable and feedthru connections. Note: With the source off, disconnect the neutralizer cable from the power supply. Use an ohm meter and measure the resistance between pins A/B and C/D. The reading should be 2 ohms or less to indicate the filament is intact and properly connected. Also check between either A/B or C/D to ground. The reading should be open to indicate the neutralizer filament is not in contact with ground. Also check between either A/B or C/D to source cable pin F. The reading should be open to indicate the neutralizer filament is not in contact with the accelerator grid. |

Electron Backstreaming

If the accelerator grid voltage is set too low, it is possible for electrons from the neutralizer to migrate into the discharge plasma. This condition is referred to as electron backstreaming. Electron backstreaming will lead to erroneous beam current readings and will result in a lower etch rate on the target (or a lower deposition rate). The source can be quickly tested to determine if electron backstreaming is taking place.



In Table 6.6 are data from an example of electron backstreaming. As the accelerator voltage is decreased from 150 to 50V, the discharge current erroneously increases at 50V. Note the beam current also increases. Similar to these data, testing for backstreaming should be conducted with a fixed cathode current. The power supply is running in manual mode.

Table 6.6. Electron back-streaming example.

| Source | Gas | Pressure | Cathode | Discharge | | Beam | | Accelerator | | Neutralizer | |
|--------|-----------|------------------|---------|-----------|-----|------|------|-------------|-----|-------------|----------|
| | | $\times 10^{-4}$ | Heater | I | V | I | V | I | V | Heater | Emission |
| | | (Torr) | (A) | (A) | (V) | (mA) | (V) | (mA) | (V) | (A) | (mA) |
| 8 cm | 5 sccm Ar | 2.6 | 3.96 | 0.33 | 55 | 100 | 1250 | 5 | 150 | 3.6 | 125 |
| | 5 sccm Ar | 2.6 | 3.96 | 0.33 | 55 | 100 | 1250 | 4 | 100 | 3.6 | 125 |
| | 5 sccm Ar | 2.6 | 3.96 | 0.33 | 55 | 100 | 1250 | 4 | 75 | 3.6 | 125 |
| | 5 sccm Ar | 2.6 | 3.96 | 0.35 | 55 | 110 | 1250 | 4 | 50 | 3.6 | 125 |

Specifications and Drawings

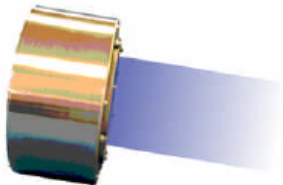
Below are specifications for the 3 and 8 cm DC sources. The pages that follow include drawings and schematics for assembly purposes.

| Specifications | 3 cm Source | 8 cm Source |
|--|--|---|
|  |  |  |
| Ion source | 3 cm | 8 cm |
| Model number | 03DC05 | 08DC04 |
| Beam size at grids | 3 cm | 8 cm |
| Beam current | 25-75 mA | 25-250 mA |
| Beam energy | 50-1200 eV | 50-1500 eV |
| Grid material | pyrolytic graphite | pyrolytic graphite |
| Beam neutralization | filament | filament |
| Cooling | radiant | radiant or water |
| Power supply | I-Beam 601 | I-Beam 601 |
| Weight | 1.1 Kg (2.5 lbs) | 5.9 Kg (13 lbs) |

